

The OPTOSCAN MONOCHROMATOR from Cairn Research is the only instrument of its type to offer control of both centre wavelength and optical bandwidth with millisecond time resolution. Combined with our signal processing modules and optical hardware it forms the heart of a powerful standalone microphotometry system, but considerable effort has also been applied to making it the ideal illumination source for Fluorescence Imaging. At Cairn we see ourselves predominately as hardware designers and system integrators so we have chosen not to develop our own imaging software and have instead sought to ensure compatibility with the excellent range of applications available on the market. Optoscan control is currently implemented in a wide range of commercial packages including Andor IQ, MDS MetaFluor/Morph, Simple PCI, RSI Neuroplex, Indec WorkBench, and Mediacybernetics InVivo. Because we are system integrators as well as hardware manufacturers we are able to provide turnkey solutions based on most of the applications above, and have sufficient knowledge of all of them to offer comprehensive support. To summarise, if your application requires fast, flexible and automated illumination control then the Cairn Optoscan may well be the instrument of choice.

Key Benefits

Sub - millisecond control of centre - wavelength with microsecond precision

Sub-millisecond bandpass control allows spectral and intensity optimisation at each wavelength

Can be used with Fg and Hg/Xe lamps as well as Xe lamps to take advantage of spectral peaks

Modular design means that the lightsource can be used independently as a white light source if required

Light guide couplings to all popular microscopes

External iris diaphragm for manual intensity control

Built-in fast electronic shuttering on all versions



Specifications

Optical configuration	Enhanced Czerny - Turner configuration with fast F/2 light collection, and off - axis parabolic mirrors to minimise aberrations
Diffraction grating	1200 line ruled grating blazed for broad UV / visible range, 1800 and 2000 line holographic gratings for demanding applications
Wavelength resolution	300 - 800nm specified with 0.5nm resolution @ +_1.5 nm accuracy
Bandwidth resolution	0 - 30nm specified with 0.1nm resolution @ +_0.2 nm accuracy
Wavelength switching	200 nm transitions in <1.5ms, 50nm transitions in < 1 ms
Bandpass switching	Typical transition times of < 1.5ms for both input and exit slits
Digital shuttering (TTL)	Typically < 2ms, depending on bandpass
Dimensions	Optoscan Monochromator box 230 x 180 x 180 system electronics units vary in size

Optoscan Monochromator

For Rapid, Intense Fluorescence Illumination

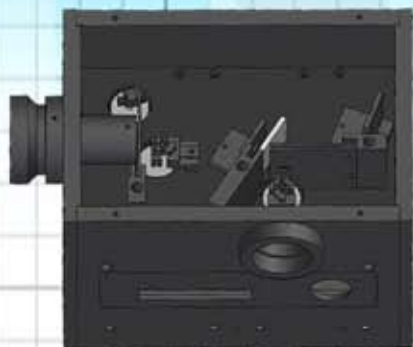

Applications

- Ratiometric photometry
- Fluorescence imaging
- Optical scanning
- Photolysis

Controller options

Microprocessor control – for photometry and general purpose illumination the Optoscan can be controlled from a front panel keypad and display (or via a PC serial port using the emulator program provided). This control unit allows a full range of built-in stepwise and scanning illumination options, and also provides the timing signals necessary to drive Cairn photometry modules (if appropriate).

Direct control – the Optoscan can also be controlled directly using analogue signals. To facilitate this we offer a complete package including a DAC card, power supply, cables, software drivers and dll library. This package works seamlessly with most commercial imaging packages to provide completely flexible illumination control in both acquisition and scan modes.

USB 2.0 control – the most powerful and cheapest way to control the Optoscan is via our embedded USB controller. This interface is the default for new systems and drivers for most software applications are currently being updated to support this option.

System options

Monochromator

Micrometer, or electronically controlled input slit

Micrometer, or electronically controlled exit slit (10msec shuttering included on micrometer version)

Standard broad spectral range diffraction grating for maximum throughput, or low inertia version for reduced switching times (but lower optical throughput)

Alternative diffraction gratings blazed for different wavelengths (as required)

Light Source

The Optosource has been designed specifically for the Optoscan monochromator, and has recently been revamped to allow the same lamphouse and power supply to drive a full range of Xe, Hg and Hg/Xe lamps from 75W to 150W. Couplings to all popular fluorescence microscopes are available from stock.

